



JK 2 and 4 Door 2.5" Lift Kit

Installation Instruction

www.teraflex.com



This Instruction set may not include all necessary instructions for your lift kit. Check every box received for additional instructions.

Kits sold with shocks will have the shock instruction in the shock packaging.

Important Notes:

Prior to beginning this or any installation read these instructions to familiarize yourself with the required steps and evaluate if you are experienced and capable to personally perform these modifications. A factory service manual should be used in conjunction with these installation instructions.

Refer to the parts list to ensure that all necessary components and hardware has been included. If any parts are missing please contact your local TeraFlex dealer for assistance.

A wheel spacer on the factory wheels, or an after market wheel with a back spacing of 4.5" or greater, will need to be used in order to clear the rear sway bar with the new links installed..

Tools needed:

- This installation guide
- Basic Mechanic Tool Set



Instructions for the following Lift Kits

JK 4 Door 2.5" Lift Kit w/ 9550 Shocks.....1251000

JK 2 Door 2.5" Lift Kit w/ 9550 Shocks.....1251002

JK 4 Door 2.5" Lift Kit.....1351000

JK 2 Door 2.5" Lift Kit.....1351002

JK 4 Door 2.5" Lift Kit w/ Shock Extensions.....1352000

JK 2 Door 2.5" Lift Kit w/ Shock Extensions.....1352002

Contents:

- Bill of Materials.....page 3 - 9
- Front Installation Instructions.....page 10 - 13
- Front Shock Extension Install.....page 12
- Rear Installation Instructions.....page 14 - 18
- Rear Shock Extension Install.....page 15
- Frame Side Track Bar Boost Install.....page 16
- Axle Side Track Bar Boost Install.....page 17
- Modify Factory Rear Brake Lines.....page 18
- Warranty and Legal Informationpage 20



JK 2.5" Lift Springs Kit

www.teraflex.com

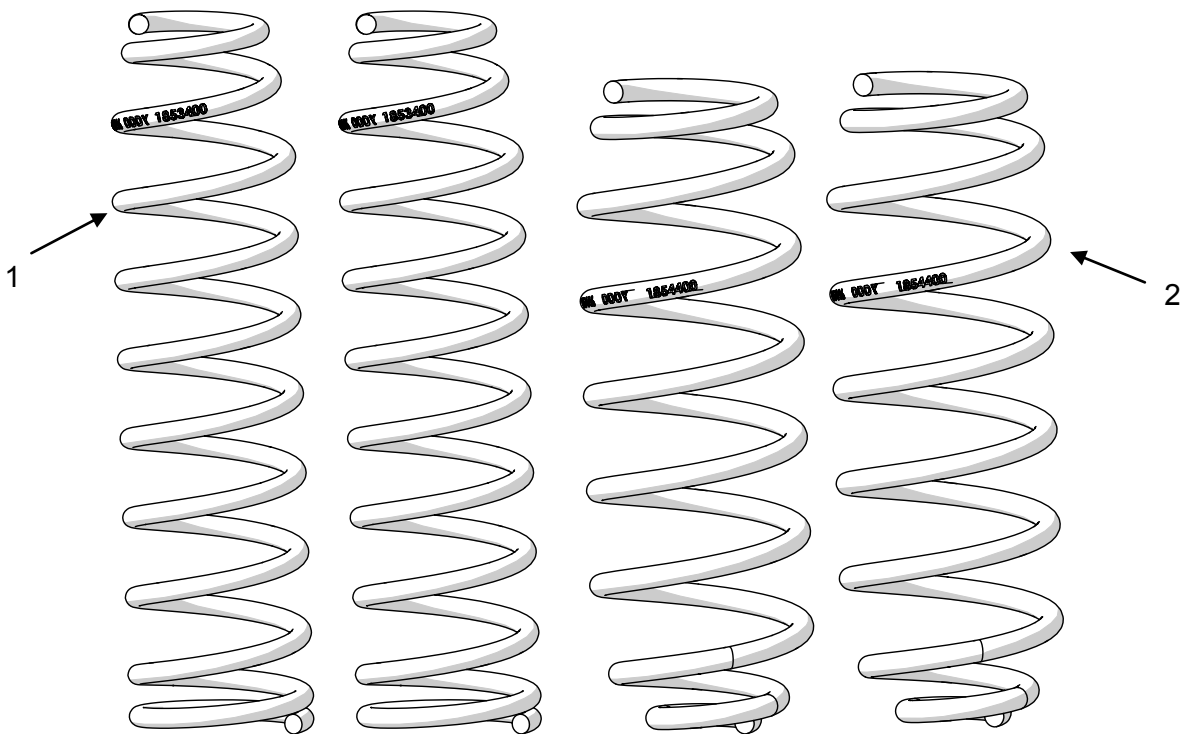

JK 2 Door Springs			
Item Number	Part Number	Description	Quantity
1	1853050	JK 2 Door 2.5" Front Springs	2
2	1854050	JK 2 Door 2.5" Rear Springs	2
JK 4 Door Springs			
Item Number	Part Number	Description	Quantity
1	1853100	JK 4 Door 2.5" Front Springs	2
2	1854100	JK 4 Door 2.5" Rear Springs	2



JK Brake Line Extension Bracket Kit

www.teraflex.com

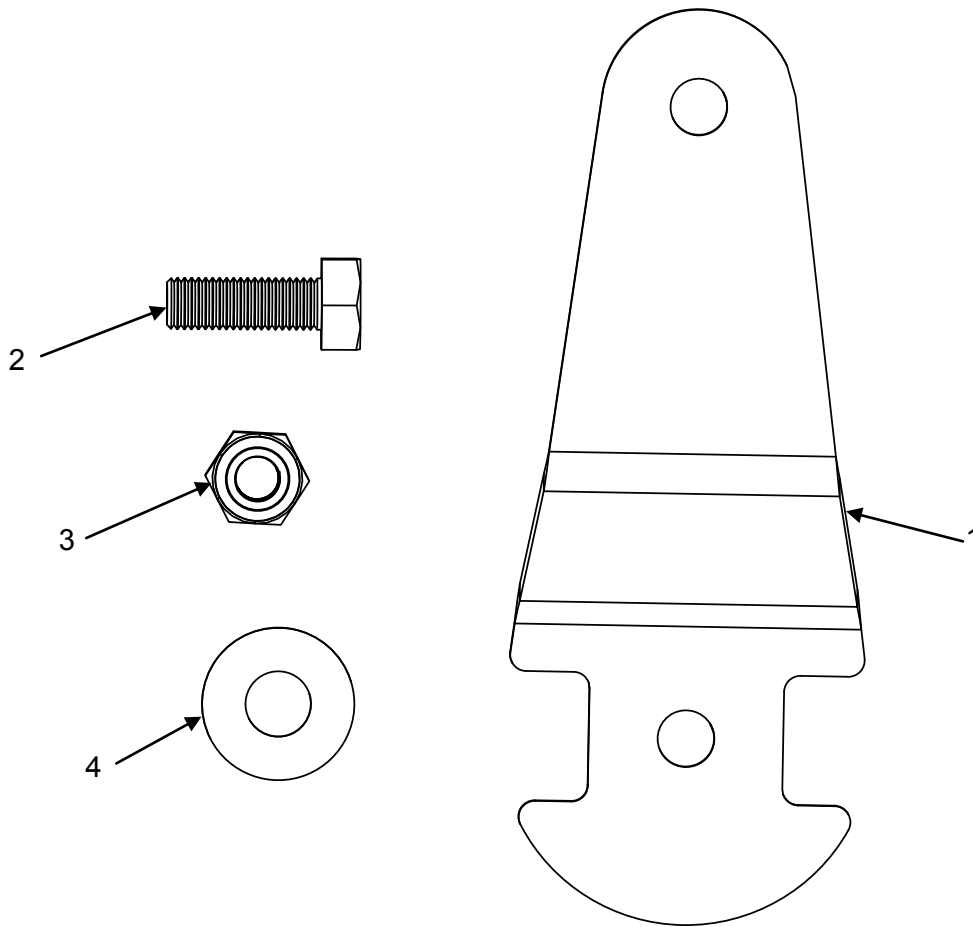

Brake Line Extension Brackets Parts List- Kit #4304400			
Item Number	Part Number	Description	Quantity
1	600276	JK Rear Brake Line Extension Bracket	2
2	77	Bolt 1/4"-28 x 3/4" Hex Head	2
3	76	Nut 1/4"-28 Nylock Zinc	2
4	458	Washer 1/4" Flat Zinc	4



JK Rear Springs Retainer Kit

www.teraflex.com

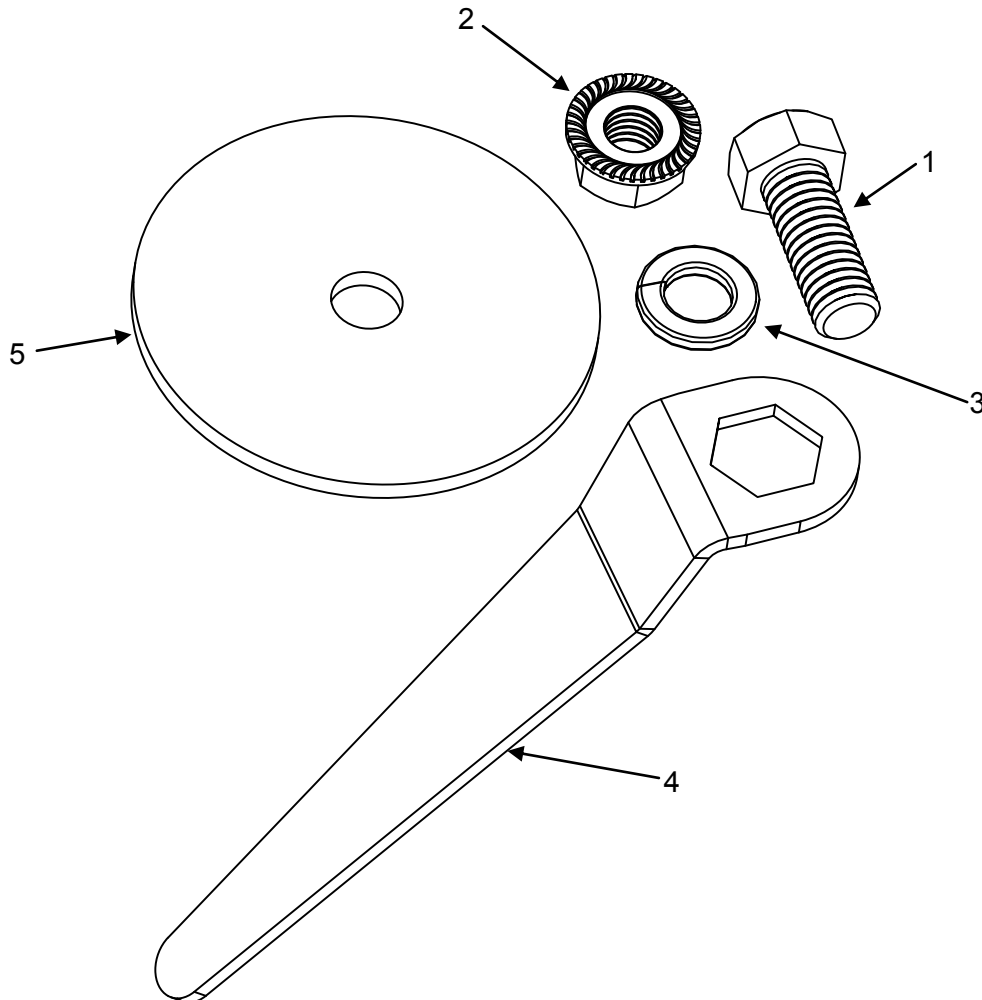

Parts List- Kit #1744014			
Item Number	Part Number	Description	Quantity
1	98	Bolt 3/8"-16 x 1" Hex Head Zinc	2
2	85	Nut 3/8"-16 Flanged Serrated	2
3	123	Washer 3/8" Lock Washer	2
4	600271	Spring Retainer Wrench Tool	1
5	600270	Lower Coil Retainer	2



JK 3"-4" Rear Swivel Stud Swaybar Link Kit

www.teraflex.com

Kit #1754500

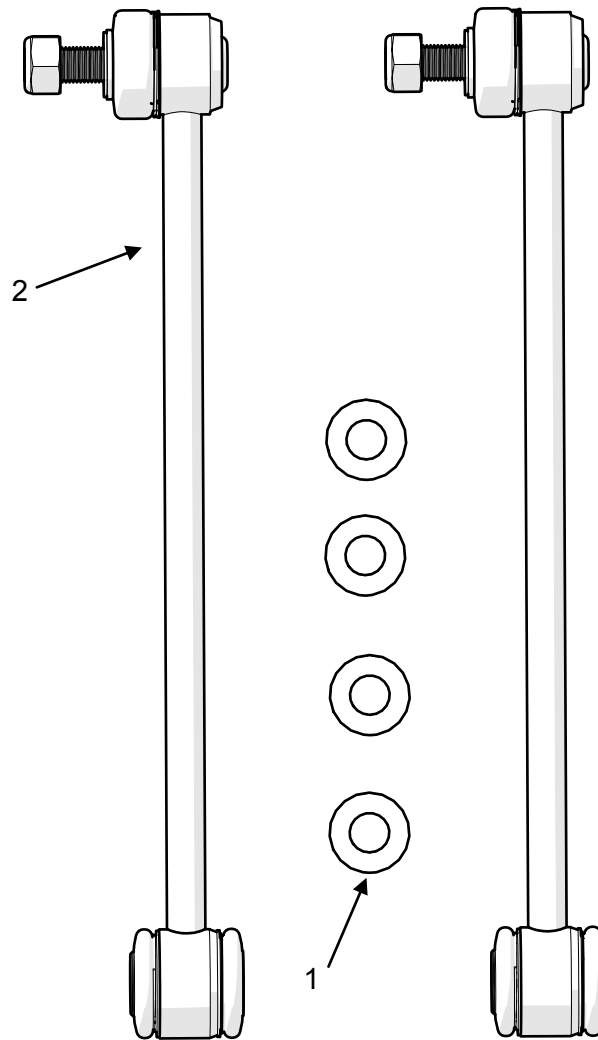

Parts List

Item #	Part #	Description	Quantity
1	37	Washer 1/2" Flat Zinc Plated	4
2	754500	Swaybar Link Rear 12.25" w/ Swivel Stud and Nylock Nut	2



JK Bumpstop Extensions Kit

www.teraflex.com

#1953800 Front Upper 2.75" Tall

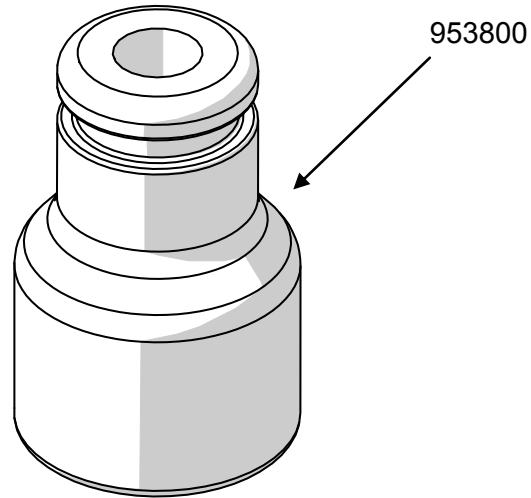

Front Bumpstops Parts Kit # 1953800

Part Number	Description	Quantity
953800	JK Front Upper Bumpstop Extension 2.75"	2

#1954700 Lower 2.75" Tall

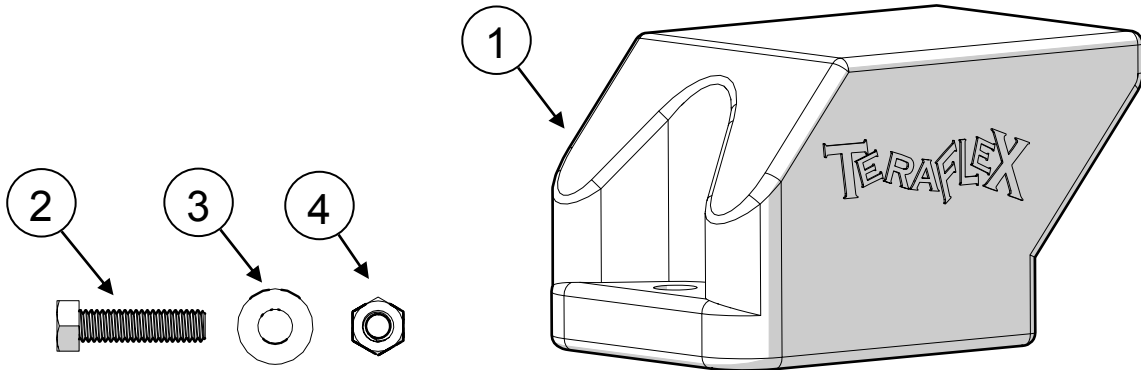

Rear Bumpstops Parts List - Kit #1954700

Item Number	Part Number	Description	Quantity
1	954700	JK Rear Lower Bumpstop 2.75" Tall	2
2	153	Bolt 5/16-18x1.25" Hex Head	4
3	38	Washer 5/16" Flat	8
4	632	Nut 5/16"-18 Stover Locknut	4



JK 2.5" Rear Track Bar Axle Bracket Kit

www.teraflex.com

Kit #1954776 for 2.5" lift

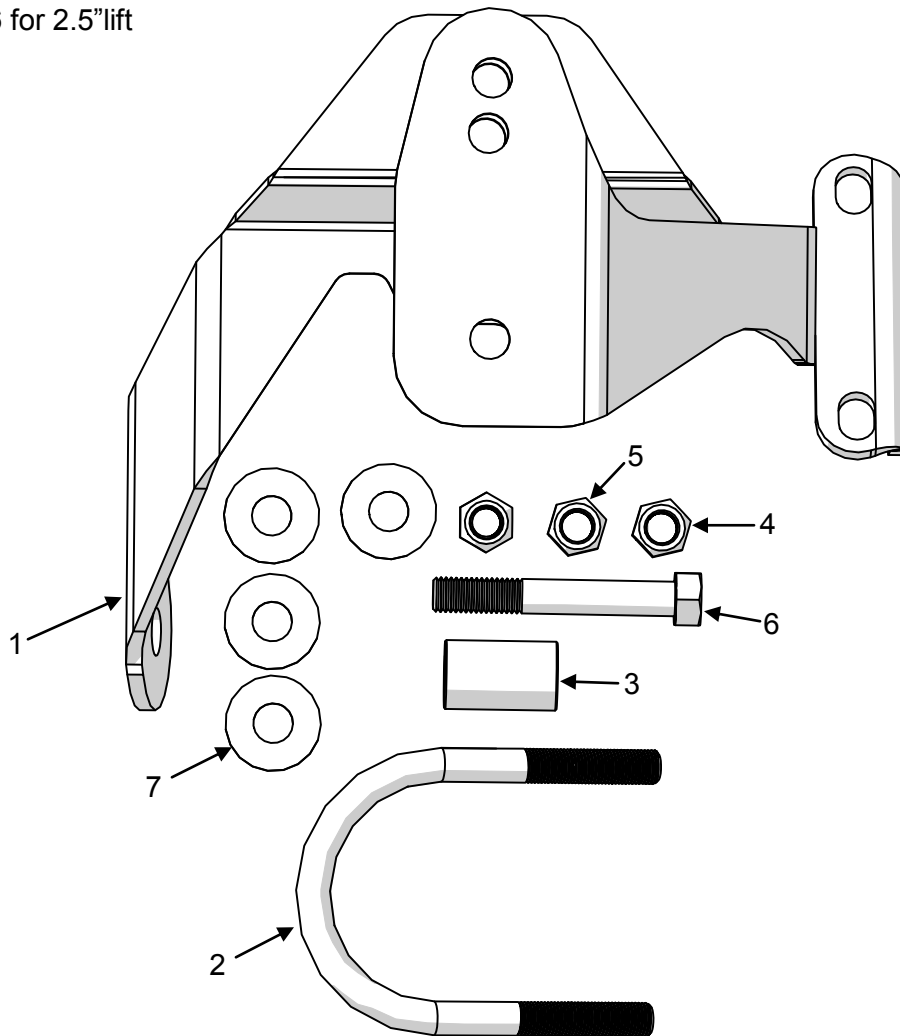

Track Bar Bracket Parts List

Item Number	Part Number	Description	Quantity
1	954776	JK Rear Track Bar Bracket 2.5"	1
2	97732	U-Bolt, Bracket	1
3	600513	Spacer Sleeve 1" OD x .5" ID x 1.62" Wide	1
4	214	Nut 1/2"-13 Stover Locknut	1
5	215	Nut 1/2"-20 Stover Locknut	2
6	242	Bolt 1/2"-13x3.5" Hex Head	1
7	37	Washer 1/2" Flat	4



JK Rear Track Bar Bracket

www.teraflex.com

#1954202

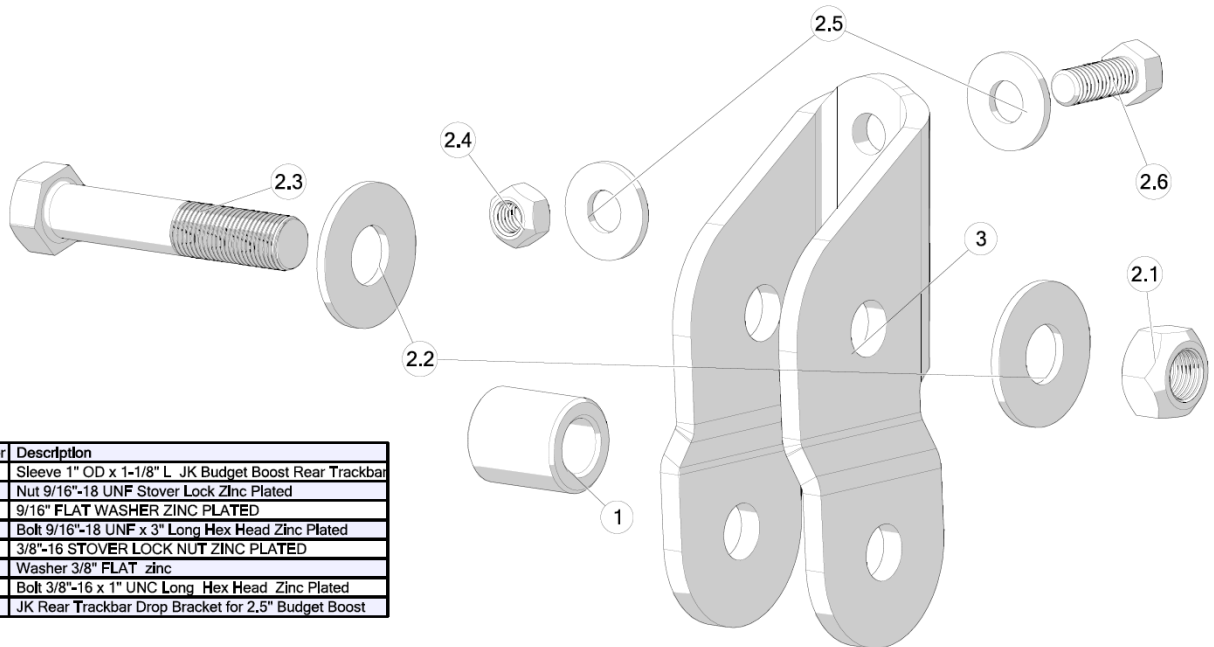

BOM ID	Part Number	Description
1	102	Sleeve 1" OD x 1-1/8" L JK Budget Boost Rear Trackbar
2.1	276	Nut 9/16"-18 UNF Stover Lock Zinc Plated
2.2	318	9/16" FLAT WASHER ZINC PLATED
2.3	6218	Bolt 9/16"-18 UNF x 3" Long Hex Head Zinc Plated
2.4	83	3/8"-16 STOVER LOCK NUT ZINC PLATED
2.5	84	Washer 3/8" FLAT zinc
2.6	98	Bolt 3/8"-16 x 1" UNC Long Hex Head Zinc Plated
3	954202	JK Rear Trackbar Drop Bracket for 2.5" Budget Boost

TeraFlex Track Bar Bracket Template

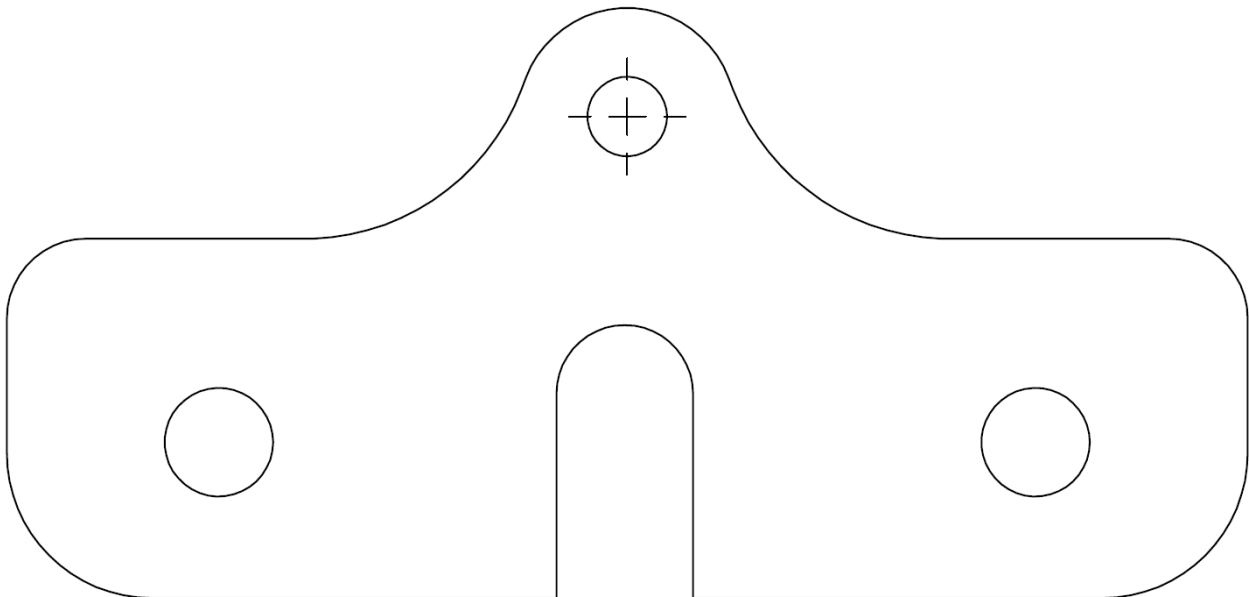

Cut this template out and tape it to the outside of the factory bracket. The tape will ensure that the template does not move while you center punch the top hole for the new TeraFlex track bar drop bracket.



JK Front and Rear Shock Extension Kit

www.teraflex.com

#1553800

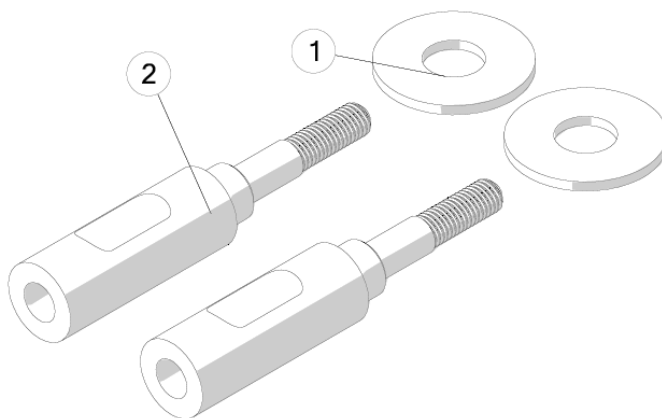

BOM ID	Part Number	Description	Qty
1	319	Washer 11/16" for JK Front Shock Extension 1.75" OD x 0.688" ID x 0.120" Thick	2
2	553800	Ext Shock Frt JK Raw 000553800	2

#1554800

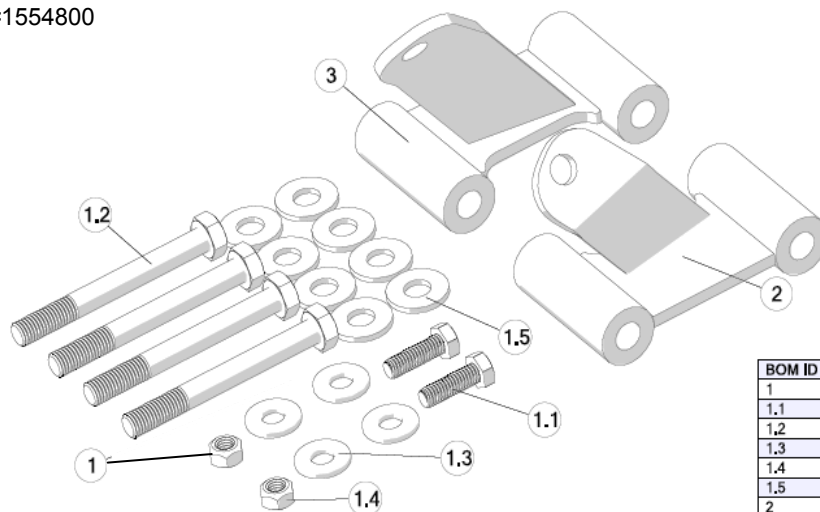

BOM ID	Part Number	Description	Qty
1	5022	Nut Bolt RR Shock Ext JK 888HRWRSXJK THB	1
1.1	152	Bolt 5/16"-18 x 1" UNC Hex Head Zinc Plated	2
1.2	158	Bolt M10 x 1.5 P x 90mm Long Hex Head Zinc Plated	4
1.3	38	Washer 5/16" Flat Zinc Plated	4
1.4	632	Nut 5/16"-18 UNC Stover Locknut	2
1.5	84	Washer 3/8" FLAT zinc	8
2	554801	Extension Shock Raw JK Rear Upper Driver	1
3	554802	Extension Shock Raw JK Rear Upper Passenger	1

FRONT REMOVAL

Refer to the factory service manual for lift locations. Raise and support the vehicle at the frame.

Remove the tires and wheels and support the axle with a jack or jack stands.

1

Loosen all front control arm bolts with a 21mm.

DO NOT REMOVE ARMS OR BOLTS.

Remove the shocks at the axle with an 18mm wrench and socket.

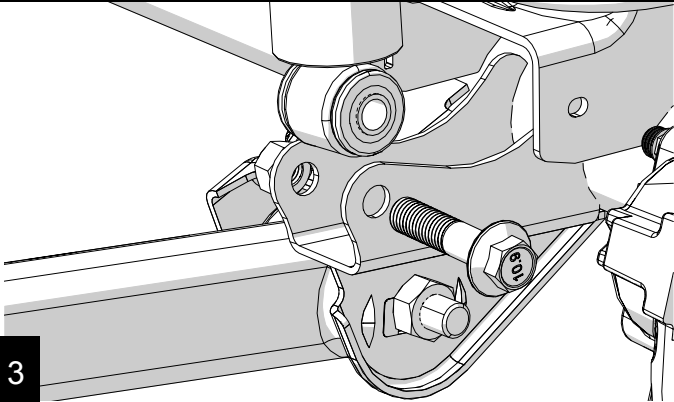

3

Remove the sway bar links with an 18mm wrench and socket at the axle. *If replacing the links, see Instructions 999027 JK Front sway bar quick disconnects.*

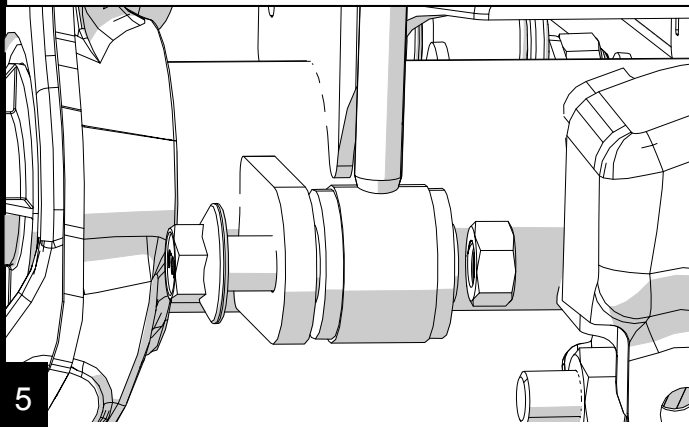

5

Remove the track bar at the axle with a 21mm. The nut is a flag nut.

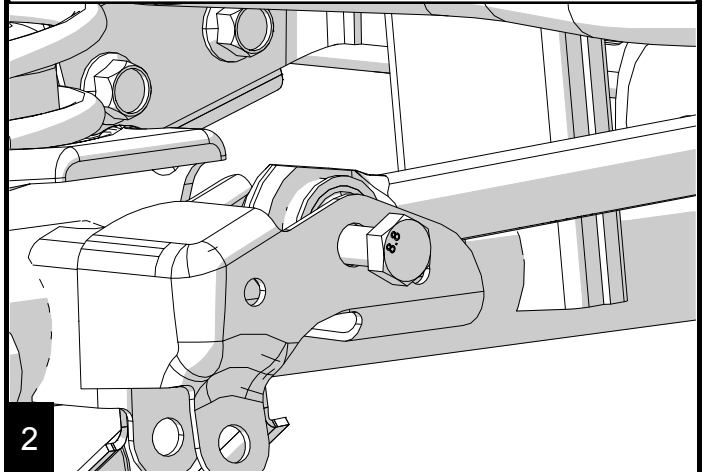

2

If NOT Installing New Shocks or Extensions SKIP this Step

With 16mm wrenches remove the upper nut, retainer and grommet from the top of the shock. On 2012+ Wranglers, the battery box interferes with access to the upper shock. Simply break away a section of the thin plastic to gain access.

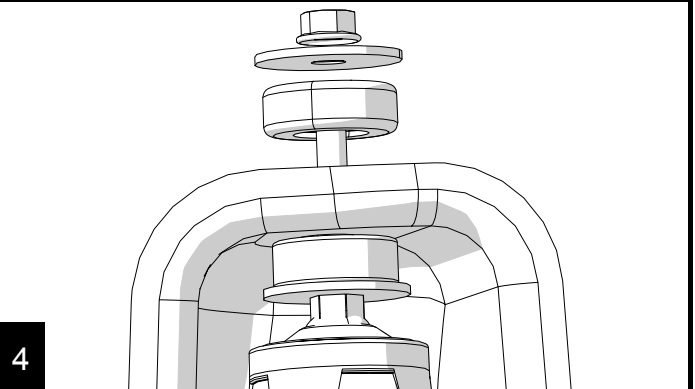

4

Lower the jack until the spring is free. Remove the coil spring. Be sure to watch the ABS, brake lines and breathers that they are not over stretched..

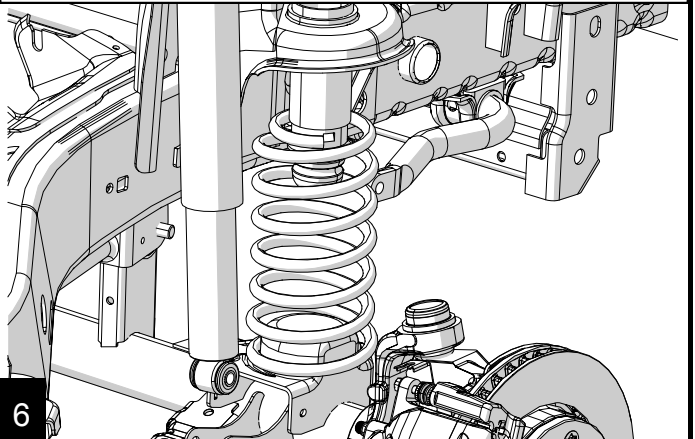

6

FRONT BUMP STOP EXTENSION INSTALL

Remove the factory bumpstop from the jounce tube by working it back and forth while twisting and pulling down.

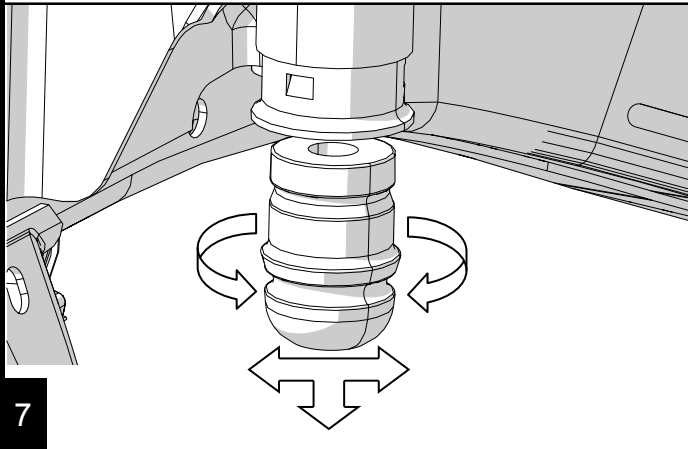

Reinstall the bumpstop by aligning the bumpstop, extension, and jounce tube. Use the hydraulic jack and raise the axle until they are seated together. A grease coating will help.

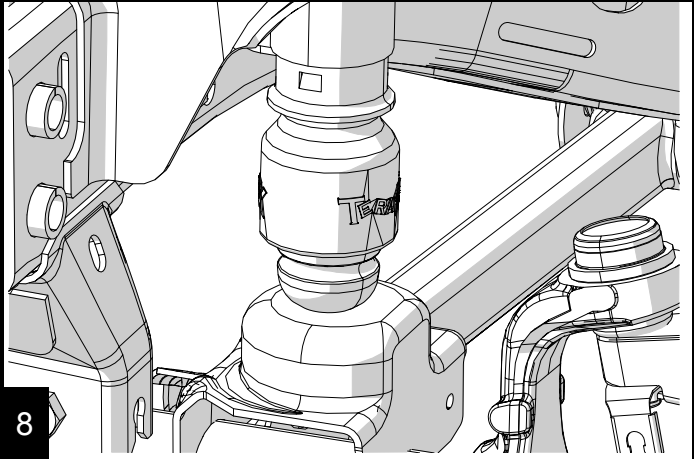

FRONT INSTALLATION

Install both coil springs, drivers side first followed by the passenger side. Rotate the spring until they are fully seated in the lower spring brackets groove.

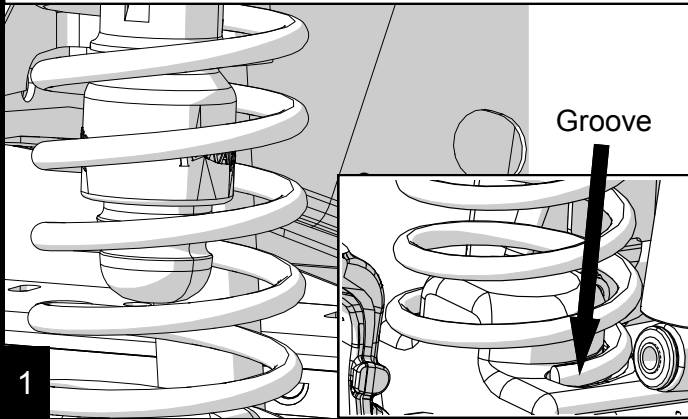

For kits with Shock Extension Brackets. Remove upper bushings from shock. Apply thread locker to stem and thread on extension. Insert supplied washer and one of the shock bushing onto extension. Install stem through the shock mount bracket. Put another shock bushing on stem, oriented as shown, followed by another washer then the nut. Torque to 20 ft-lbs or until the bushings compress about 1/8".

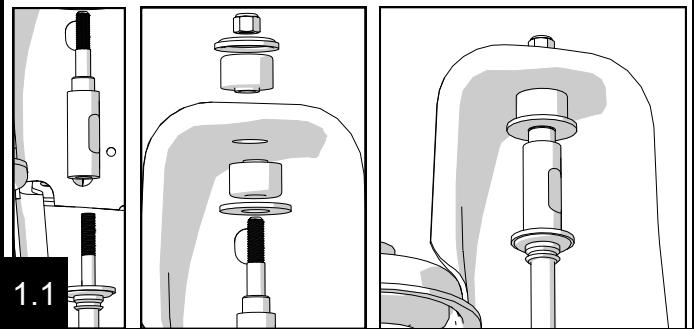

If replacing the shocks do so now, see instructions 999160 JK Shock Installation.

Raise the jack high enough to install the shock bolts.
Torque to 56 ft-lbs (76 Nm).

Reinstall the sway bar links or install new links if supplied.
Torque top and bottom to 75 ft-lbs.

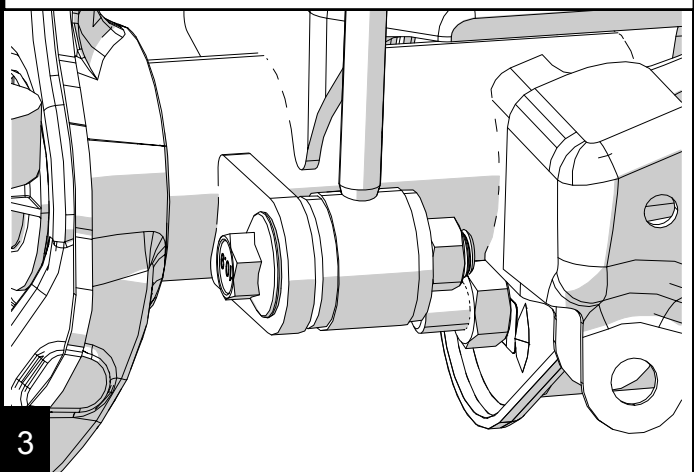
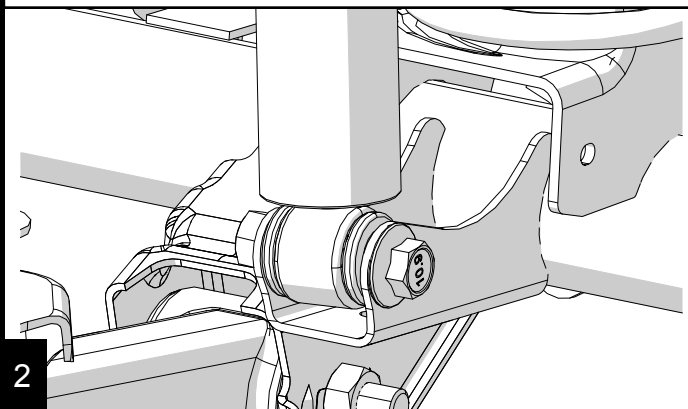

Reinstall wheels and tires. Torque lug nuts to 95-115 ft-lbs. **Once the vehicle is on the ground**, torque the upper control arm bolts to 75 ft-lbs and the lower control arm bolts to 125 ft-lbs.

Reinstall the front track bar and torque the Track Bar bolt to 125 ft-lbs.

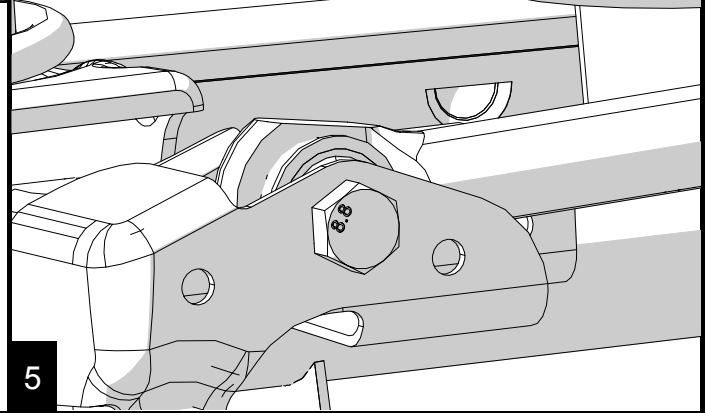
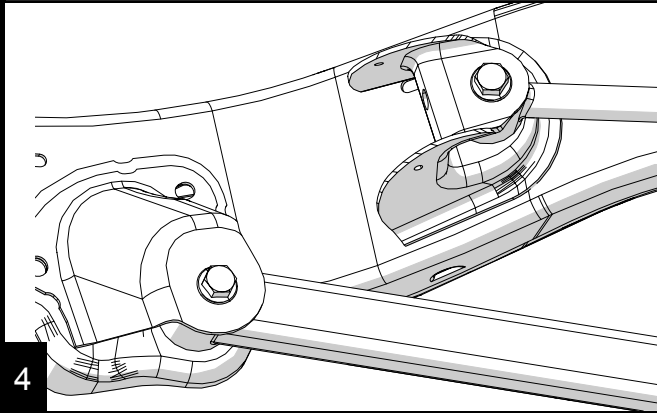

REAR REMOVAL

Remove the rear track bar at the axle with a 21mm. **If your lift kit did not come with frame side track bar boost skip to step 4**

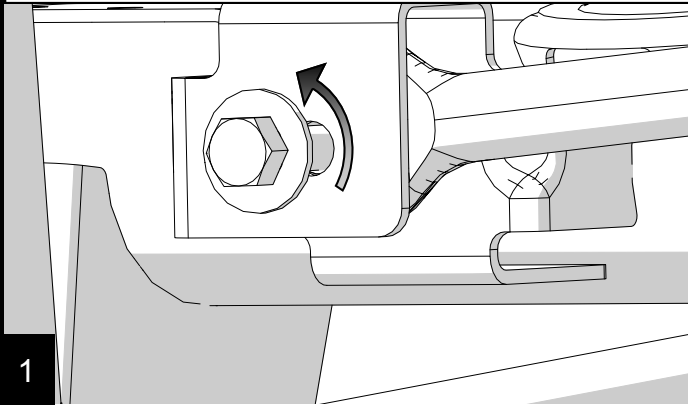

1

For frame side track bar boost remove the frame side track bar bolt with an 18mm and remove the track bar.

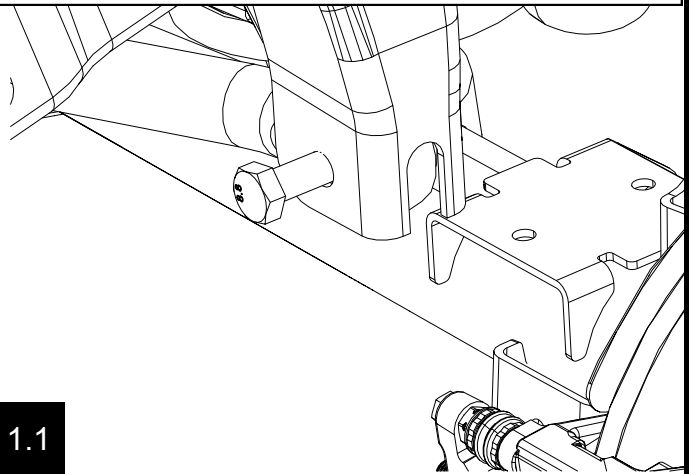

1.1

With a 21mm loosen all rear control arm bolts. **DO NOT REMOVE ARMS OR BOLTS.**

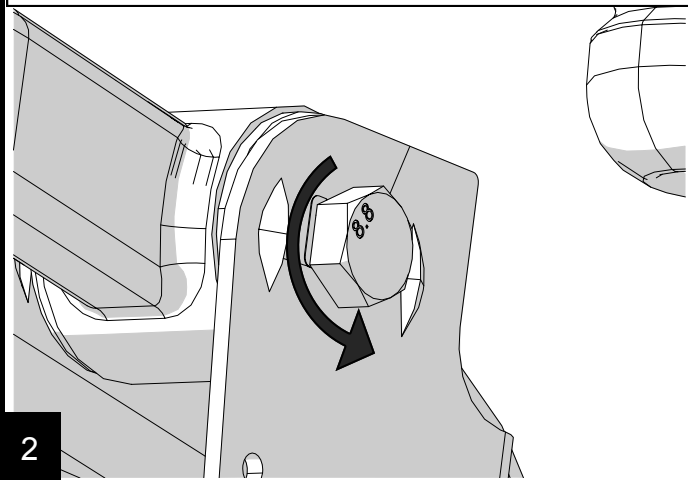

2

Remove the shocks at the axle with an 18mm wrench and socket. **If replacing the shocks, see instructions 999160 JK Shock Removal and Installation.**

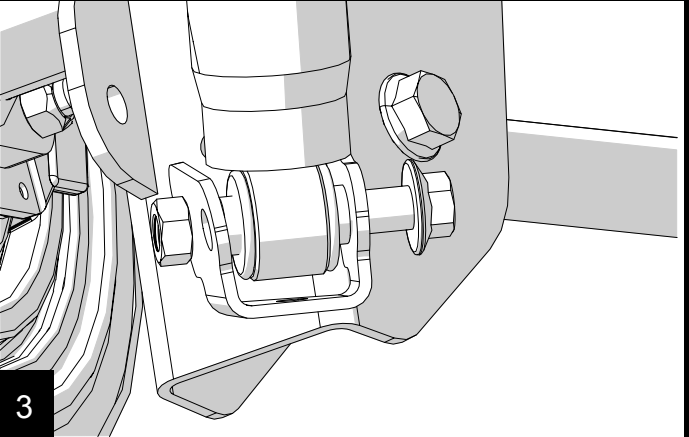

3

Remove the clips that secures the ABS wiring harness to the upper control arm mount. Remove the parking brake cable bracket from the underside of the body with a 10mm deep socket and discard bracket.



4

Remove the brake line mount from the frame with a 10mm.

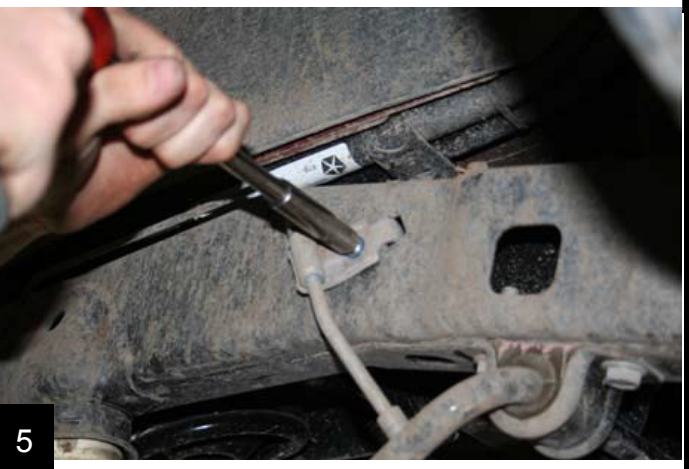

5

Carefully lower the axle enough to remove the spring. Be sure to watch the ABS, brake lines and breather tubes for overextension. Remove the old spring.

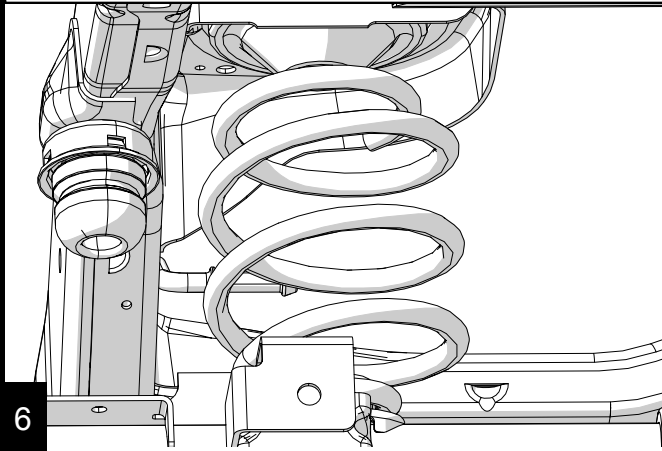

6

REAR INSTALLATION

Install the new springs. Make sure to reuse the factory spring isolator.

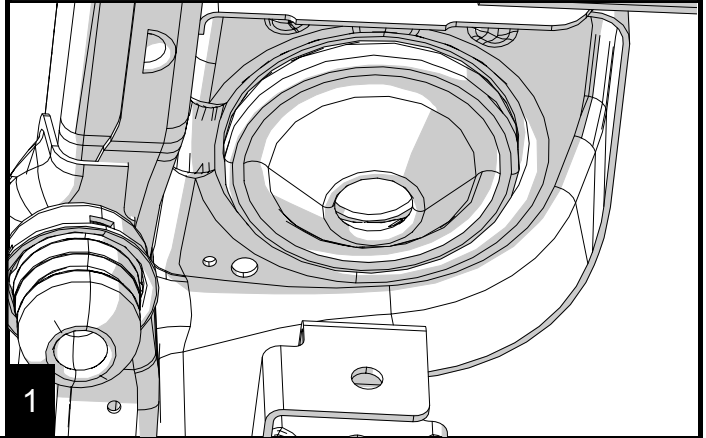

1

Skip to step 2 if your lift kit did not come with Extension Bracket. For the rear shock extensions finish removing the rear shocks. Apply penetrating oil. These are captured nuts and a broken bolt here is a real inconvenience. Remove the two upper bolts with a 16mm.

Install the left rear shock extension. Using the supplied 5/16" bolt and nut, hold the extension bracket into place. Start one of the M10 x 90 mm long bolts and washer.

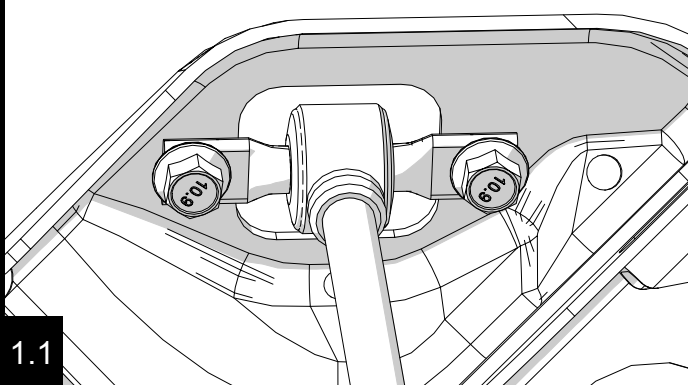

1.1

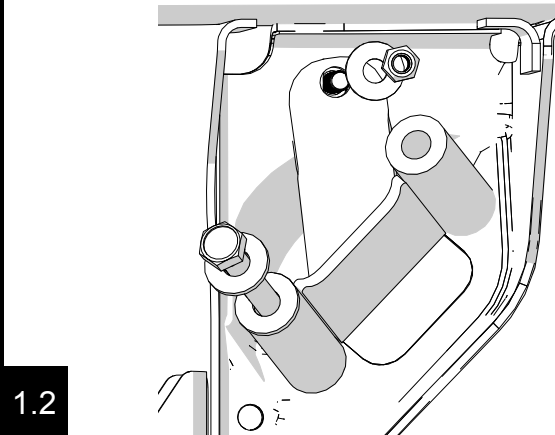

1.2

Position open end of shock bar pin onto bracket and M10 bolt that was started, then install the other M10 bolt and washer. Torque M10 bolts to 37 ft-lbs. Tighten the 5/16" bolt.

Raise the axle high enough to reinstall the lower shock bolts. Torque to 56 ft-lbs. Torque to 16 ft-lbs. If your kit came with Shock Extensions see step 4 and 5

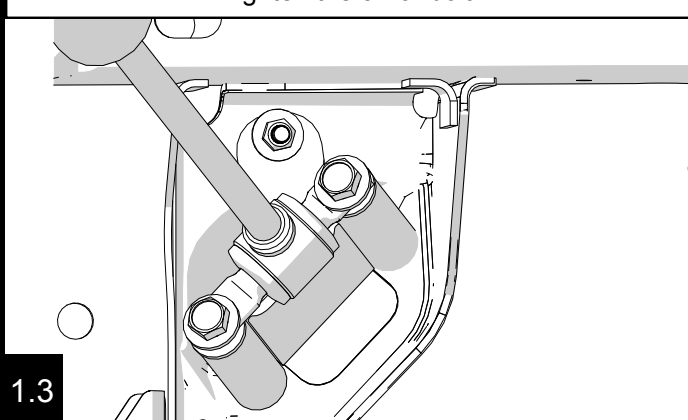

1.3

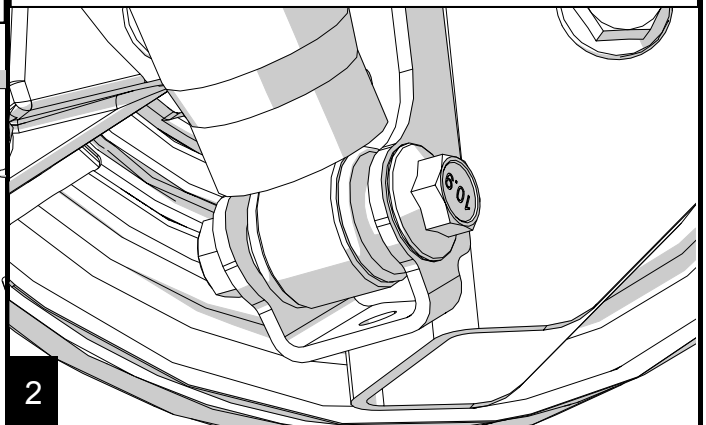

2

Place the retainer on the lower spring pad.

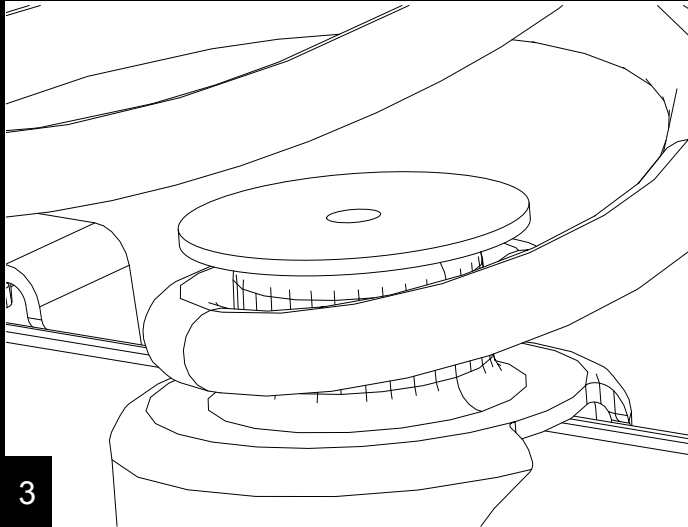

3

Install the 3/8" bolt and lock washer through the spring retainer and spring pad. Place a nut into the provided tool. Slide the tool underneath the spring pad from the front of the axle and thread the bolt into the nut.

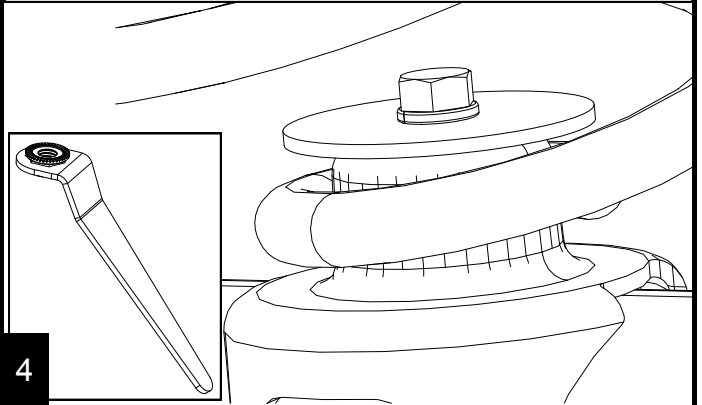

4

Torque the bolts to 30 ft-lbs (41 Nm)
If your kit did not come with a frame side tack bar boost skip to page 15

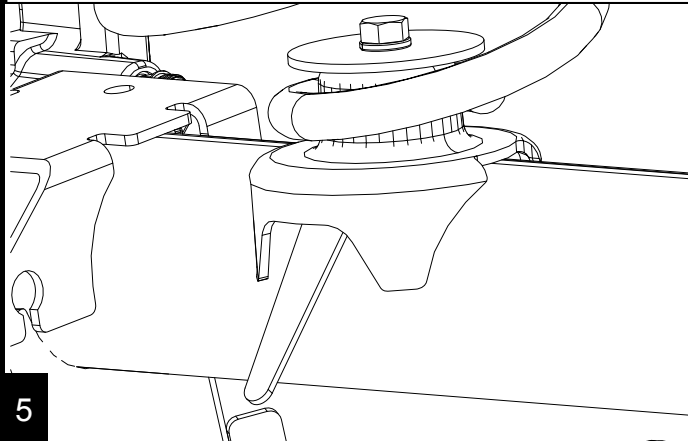

5

Frame side track bar boost install: Cut out the provided template and wrap it around the track bar bracket. Index the factory holes with the template holes then mark and drill the indicated 3/8" hole.

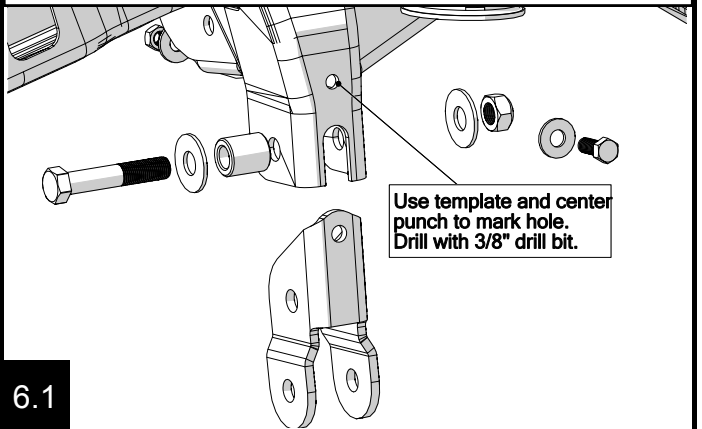

6.1

Use template and center punch to mark hole. Drill with 3/8" drill bit.

Install the bracket with the provided hardware as shown. Be sure to place the sleeve in factory bracket to avoid crushing.

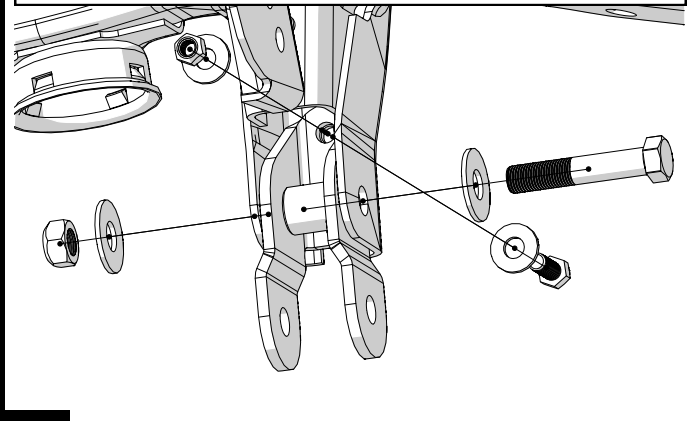

6.2

Torque the 9/16" bolt to 125 ft-lbs and the 3/8" bolt to 45 ft-lbs.

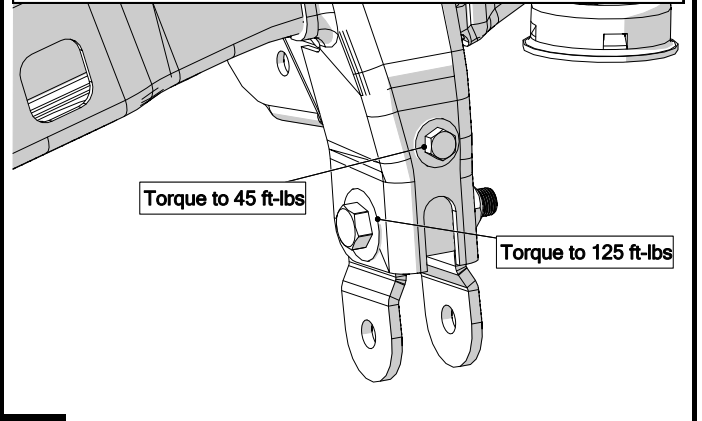

6.3

Torque to 45 ft-lbs

Torque to 125 ft-lbs

Position the TeraFlex bracket so it installs over the factory bracket and lines up with the lower control arm bolt. Reinstall the control arm bolt finger tight.

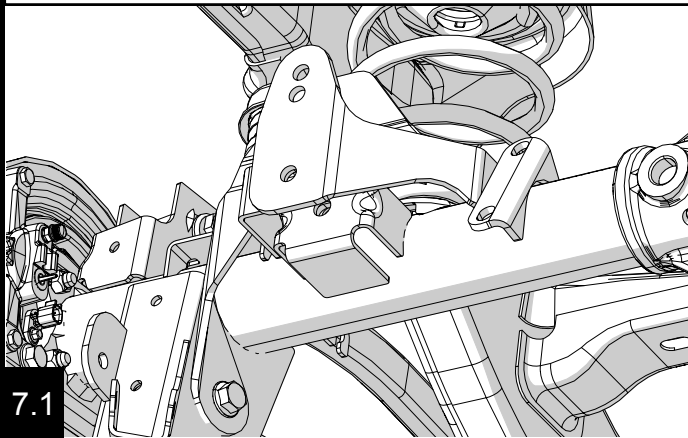

7.1

Use the provided sleeve as a spacer and install the 1/2"x3.5" bracket bolt with washers on either side and a locknut. Torque to 75 ft-lbs.

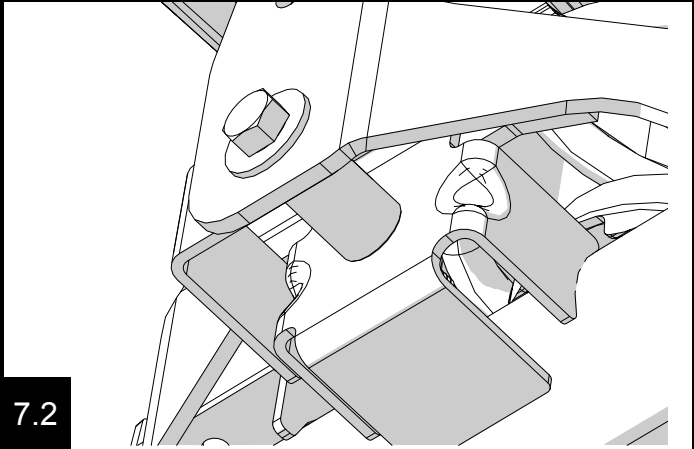

7.2

Install the U-bolt around the axle and into the bracket. Torque the nuts to 45 ft-lbs.

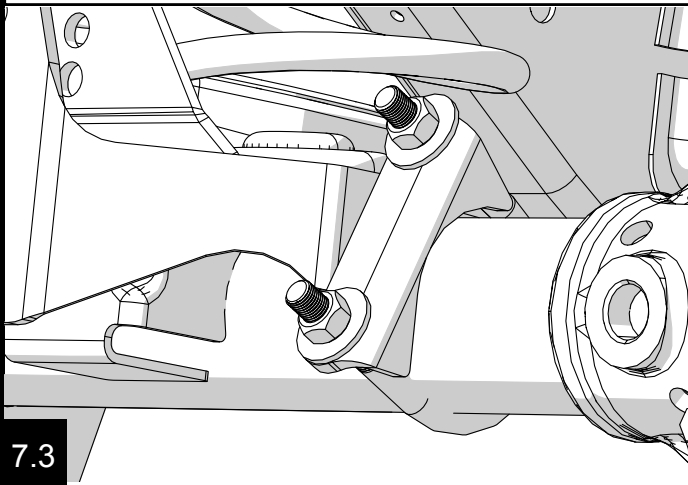

7.3

Reinstall lower control arm bolts **but do not tighten**. Reinstallation of track bar will be done once the Jeep is back on the ground.

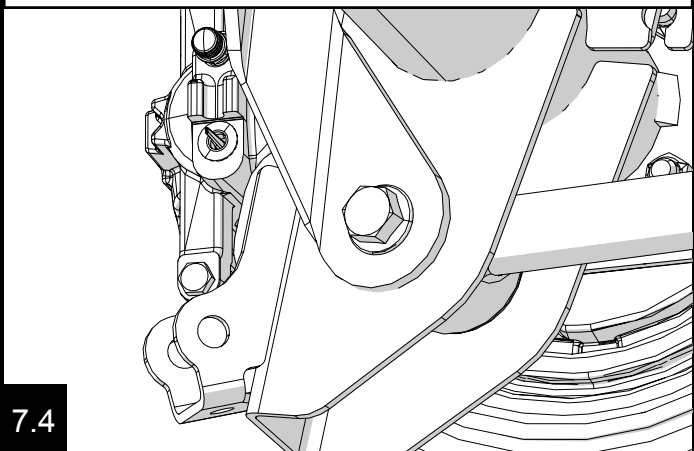

7.4

Using the 18mm socket and wrench, remove the bolt holding the factory sway bar link to the axle bracket.

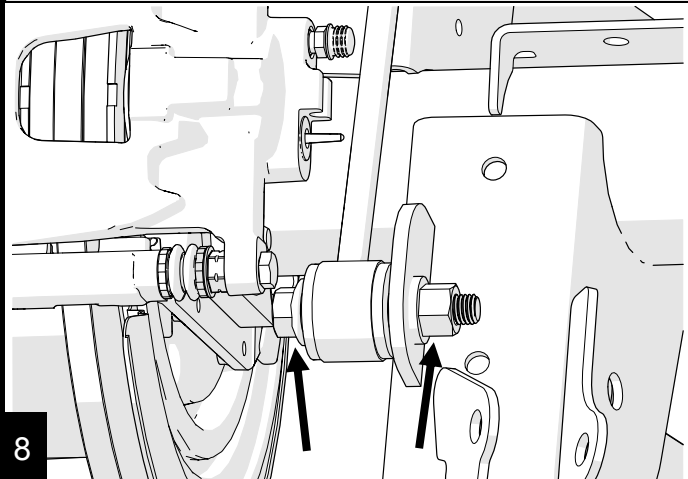

8

Using a 19mm wrench to hold the stud from turning and an 18mm to remove the nut, remove the link form the sway bar. Repeat steps 2 and 3 on other side.

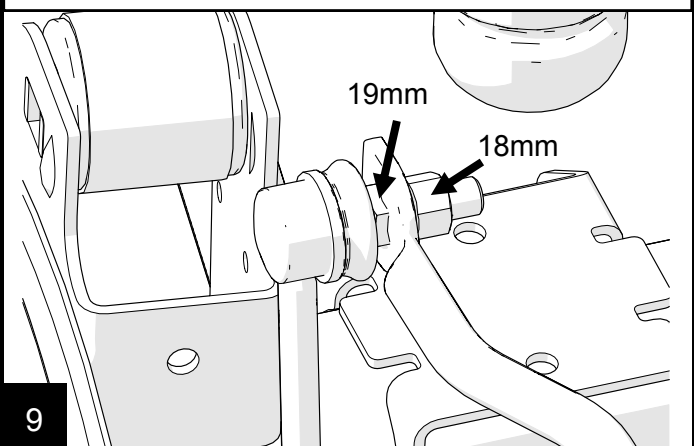

9

With both factory links removed, install the swivel end of the link into the sway bar from the outside. Install the new lock nut using the 19mm end wrench and a 6mm allen wrench. Torque to 66 ft-lbs

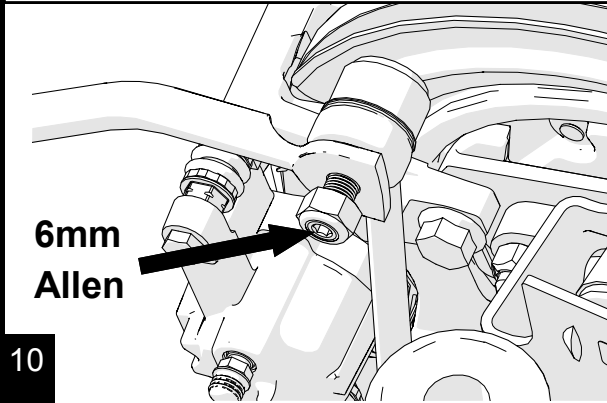

Reinstall the factory hardware as well as two provided washers on the lower end of the link. Place the washers on either side of the bushing. Torque to 75 ft-lbs.

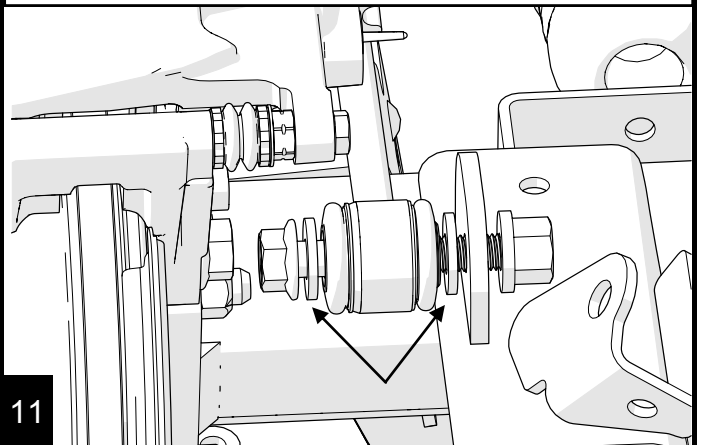

Install the bracket to the frame using the factory bolt. Note orientation with the bend inwards. Torque to 48 in-lbs (5.4 Nm)

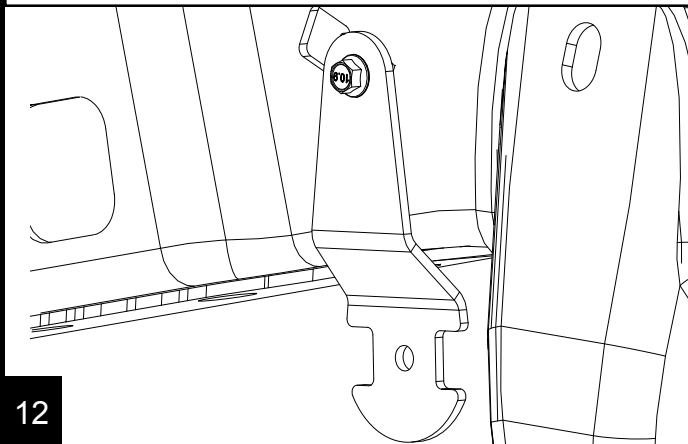

Using a 7/16" wrench and the supplied hardware, bolt the brake line to the bracket with a washer on both sides. Torque bolt to 120 in-lbs. (13 Nm). Press the hard brake line against the frame to avoid contact with the sway bar links as the suspension cycles.

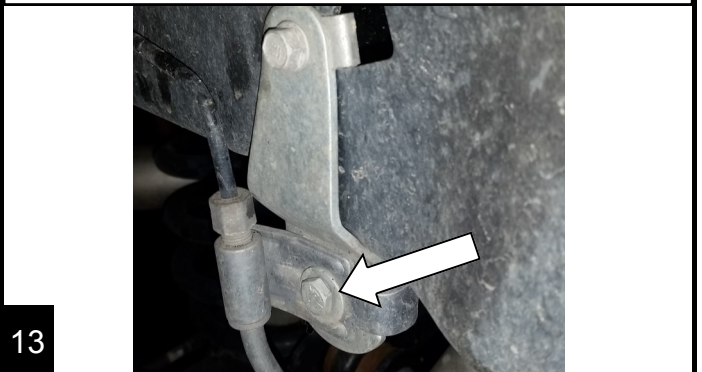

Straighten the factory hard brake line, a touch, to allow for less tension with suspension droops.

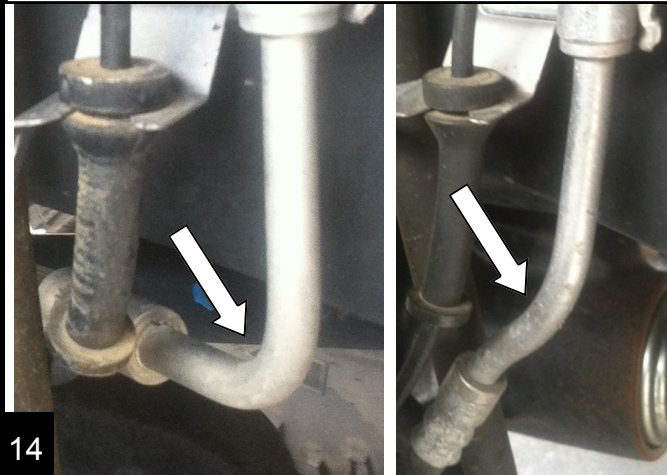

REAR BUMPSTOPS

Align the extension on the factory pad with the "shelf" towards the front of the vehicle. Install the provided bolts with washers into the two holes. Torque to 25 ft-lbs.

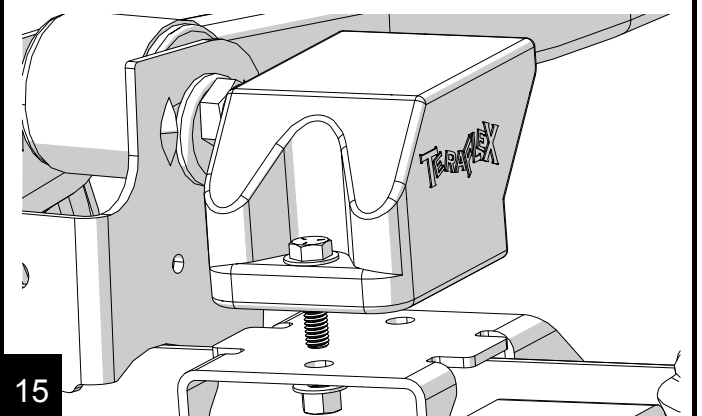

Reinstall wheels and tires, torque to 95-115 ft-lbs. Lower to the ground. Torque all upper control arm bolts to 75 ft-lbs and all lower control arms to 125 ft-lbs.

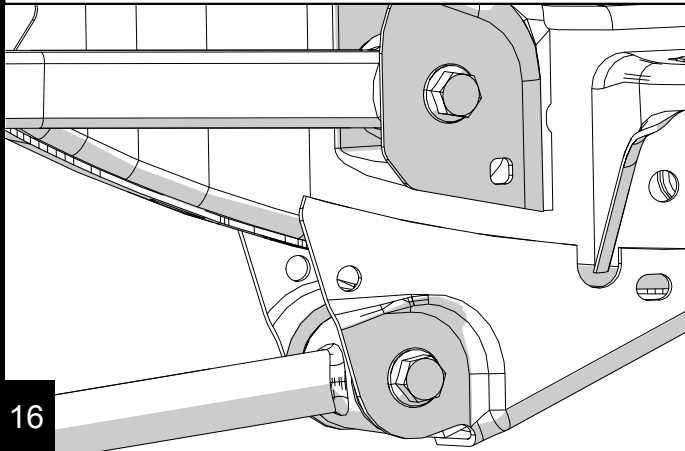

16

For Axle Side Track Bar Boost: Reinstall the rear track bar using the upper hole and factory hardware. Have someone push on the body to help align the bolt holes. Torque to 125 ft-lbs.

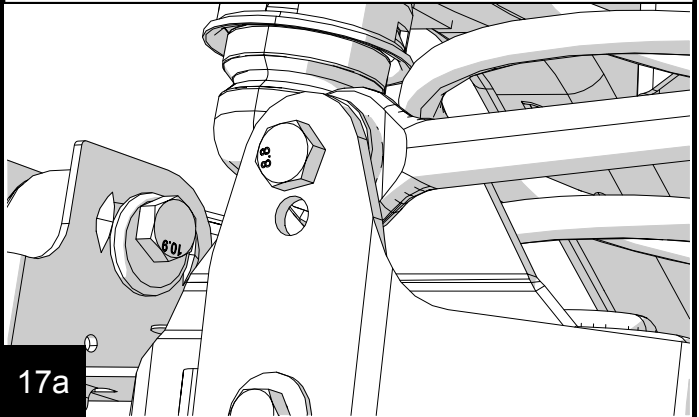

17a

Reinstall the rear track bar at the axle. Have someone push on the body to help align the bolt holes. Torque to 125 ft-lbs.

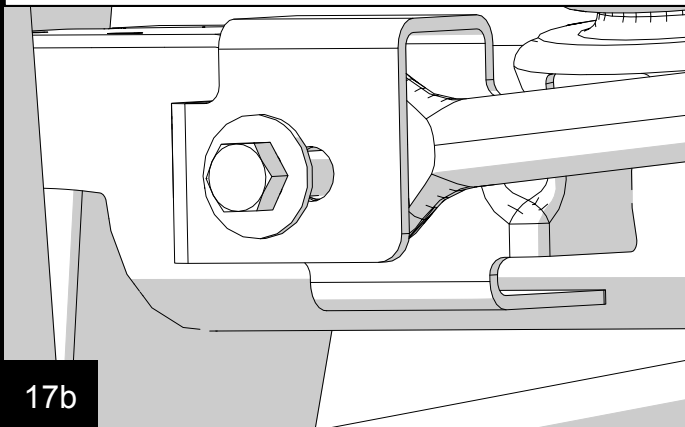

17b

Check torque for all bolts and nuts.

Re-torque all bolts and nuts after the first 100 miles

To straighten the steering wheel, loosen the adjuster sleeve on the drag link with a 15mm. Make a mark across the sleeve and threads to indicate the original position. Looking from the drivers side, rotate the adjuster sleeve counter clockwise 3/4 of a turn. This should be pretty close. Every vehicle is different, test drive yours and adjust as needed. Torque the pinch clamp bolts to 45 ft-lbs.

18

PRODUCT INFORMATION

MAINTENANCE INFORMATION:

It is the buyer's responsibility to have all suspension, drivetrain, steering, and other components checked for proper tightness and torque after the first 100 miles and every 3000 miles after that.

NOTICE TO INSTALLER:

The enclosed "Warning to Driver" sticker must be installed in the vehicle in driver's view. This sticker is to act as a constant safety reminder when operating the vehicle. It is your responsibility as the equipment installer to install the provided sticker and to forward the product instructions to the vehicle's owner for review. If a "Warning to Driver" sticker or product installation guide were not included in the kit, FREE replacement stickers and instructions are available by request. It is the installer's duty to ensure a safe and controllable vehicle after the modifications have been performed.

WARNING:

Neither the seller nor the manufacturer will be liable for any loss, damage, or injury directly or indirectly arising from the use of or inability to determine the use of these products. Before using, the user shall determine the suitability of the products for its intended use, and the user shall assume all responsibility and risk in connection therewith.

WARNING TO DRIVER:

This vehicle has been modified to enhance off road performance and has unique handling characteristics. Use in harsh environments can cause extreme stress on the components. Vehicle should be inspected after being off road to make sure that all the components are in working order and safe to travel on the highway. All fasteners should be checked so that they are at the correct torque specifications as the vibration and stresses from off roading may cause critical fasteners to work loose. Extra care should be taken to inspect the critical components, steering, and brake systems. During each oil change components such as arms, tie rod ends, etc should be greased and checked for excessive wear. Any worn components should be replaced. When returning to the pavement always set or restore tire air pressure to the factory recommendation and connect or engage any disabled sway bar mechanisms. Because of the higher center of gravity and larger tires, this vehicle handles and reacts differently than many passenger cars, both on and off road. You must drive it safely! Extreme care should be taken to prevent vehicle rollover or loss of control, which can result in serious injury or death. Avoid sudden sharp turns or abrupt maneuvers. Generally, braking performance and capabilities are decreased when significantly larger/heavier tires are used, especially when used in combination with transfer case low-range reduction kits. Take this into consideration while driving. Do not add, alter or fabricate any factory or aftermarket parts to increase vehicle height over the intended height of the TeraFlex product purchased. Mixing component brand is not recommended. TeraFlex Inc. will not be responsible for any altered product or any improper installation or use of our products. We will be happy to answer any questions concerning the design, function, and correct use of our products. It is ultimately the buyer's responsibility to have all bolts/nuts checked for tightness after the first 100 miles and then every 3000 miles. Wheel alignment, steering system, suspension and drive line systems must be inspected by a qualified professional mechanic at least every 3000 miles.

TERAFLEX PRODUCT WARRANTY:

TeraFlex Inc. warrants TeraFlex Suspension products to the original retail purchaser to be free of defects in material and workmanship for as long as the original purchaser owns the vehicle on which products were originally installed.

Failure to complete regular maintenance (grease every 3000 miles) on TeraFlex FlexArms will void this warranty. All other conditions of the standard TeraFlex product warranty apply.

All TeraLow products are covered by the TeraFlex two (2) year warranty to be free of defects in material and workmanship for two years from date purchased.

TeraFlex axles are covered by a 12-month warranty to be free of defects in materials and workmanship.

This warranty does not cover or include product finish, improperly installed or applied products, improperly maintained products, products or components used for racing or competition or damage due to abuse or neglect, products that fail due to the use of larger tire and wheel combinations.

All returns must be accompanied by an original invoice. It is the customer's responsibility to remove the product from the vehicle. Shipping charges are the responsibility of the customer. TeraFlex Inc. will pay the return freight if the product meets the terms of warranty.

This warranty is for the replacement or repair of defective TeraFlex products only and does not include freight charges, labor charges for removal of or installation of TeraFlex or related products or components, costs incurred due to down time of the vehicle, or lost profits due to vehicle down time.

A returned goods authorization number (RGA#) must accompany any returned products. For more information please contact a TeraFlex customer service representative.

COPYRIGHT

©Copyright 2014. All rights reserved, TeraFlex Inc. Reproduction of this catalog and/or any of its contents without written permission is strictly prohibited.

TeraFlex® is a registered trademark of TeraFlex Inc. All trade names and logos including but not limited to TeraFlex, FlexArms, RockGuard, Monster, and LCG are protected by law and duplication of trade names and/or logos are strictly prohibited.

TeraFlex Inc. reserves the right to update, discontinue, redesign, modify finish, part number or component build parts if deemed necessary without written notice. TeraFlex Inc., and any associated dealers are not responsible for misprints or typographical errors that may have inadvertently been made within this instruction sheet.

Jeep® and the Jeep® grill are registered trademarks of Fiat Chrysler Automobiles N.V., and have no affiliation with TeraFlex Inc.

TERAFLEX, Inc.

5680 West Dannon Way
West Jordan, Utah 84081
Phone/801.713.3314
Fax/801.713.2313
www.teraflex.com